

A Wideband Fixed-Tuned SIS Receiver for 200-GHz Operation

Raymond Blundell, *Member, IEEE*, Cheuk-Yu E. Tong, *Member, IEEE*, D. Cosmo Papa, R. Louie Leombruno, Xiaolei Zhang, *Member, IEEE*, Scott Paine, *Member, IEEE*, Jeffrey A. Stern, Henry G. LeDuc, and Bruce Bumble

Abstract—We report on the design and development of a heterodyne receiver, designed to cover the frequency range 176–256 GHz. This receiver incorporates a niobium superconductor-insulator-superconductor (SIS) tunnel junction mixer, which, chiefly for reasons of reliability and ease of operation, is a fixed-tuned waveguide design. On-chip tuning is provided to resonate out the junction's geometric capacitance and produce a good match to the waveguide circuit. Laboratory measurements on the first test receiver indicate that the required input bandwidth (about 40%) is achieved with an average receiver noise temperature of below 50 K. Mixer conversion gain is observed at some frequencies, and the lowest measured receiver noise is less than 30 K. Furthermore, the SIS mixer used in this receiver is of simple construction, is easy to assemble and is therefore a good candidate for duplication.

I. INTRODUCTION

THE FIRST RADIO astronomy observations of the millimeter-wave molecular transitions of CO and CN were made in 1970 [1], [2]. Since that time, millimeter-wave radio astronomy has evolved considerably: numerous millimeter-wave observatories are now in routine operation and receiver technology has reached a high degree of maturity [3]. At submillimeter wavelengths this is not the case. There are only two specially designed ground-based submillimeter-wave observatories in routine operation: the Caltech Submillimeter Observatory and the James Clerk Maxwell Telescope. A number of other submillimeter-wave observatories are being developed (e.g., the Submillimeter Telescope, a joint project between the University of Arizona and the Max Planck Institut für Radio-astronomie) or are under construction (e.g., the Antarctic Submillimeter Telescope Remote Observatory).

The Submillimeter Array (SMA), currently under construction at the Smithsonian Astrophysical Observatory, will be the first submillimeter-wave synthesis telescope. Consisting of six 6-meter antennas, each to be equipped with eight SIS receivers designed to operate throughout the major atmospheric windows from below 200 GHz to above 900 GHz, the SMA will benefit from the rapid evolution of niobium SIS mixer technology.

Manuscript revised November 15, 1994.

R. Blundell, C.-Y. E. Tong, D. C. Papa, R. L. Leombruno, X. Zhang, and S. Paine are with the Harvard-Smithsonian Center for Astrophysics, Cambridge, MA 02138 USA.

J. A. Stern, H. G. LeDuc, and B. Bumble are with the Center for Space Microelectronics Technology, Jet Propulsion Laboratory, California Institute of Technology, Pasadena, CA 91109 USA.

IEEE Log Number 9409121.

II. MIXER DESIGN

Given that many SIS receivers currently operate in the 1.3-mm atmospheric window [3], the lowest-frequency unit appears to be the easiest of the SMA receivers to design. However, a number of factors render its design more difficult. For example, operating at its lowest frequency, with an intermediate frequency (IF) of 5 GHz, the signal to IF ratio is only a factor of 30, compared to about 100 typical of most working SIS receivers. Extra care is therefore required in the design of on-chip mixer tuning so as not to inadvertently short out part of the IF signal. Also, since the interferometer will operate at a remote high altitude site, where mechanical tuning of the mixer circuit is excluded, a fixed-tuned design with instantaneous input bandwidth in excess of 40% is required.

Current technology dictates the choice of a waveguide based mixer with a corrugated feed for high efficiency operation. The large instantaneous signal bandwidth is most readily achieved using an inductively compensated SIS junction. The mixer mount is therefore chosen to present a real impedance at the junction feed point across the signal input band. Furthermore, since the mixer output is reasonably coupled to the 50- Ω IF amplifier network, without the introduction of a specific IF matching circuit, by using a junction with normal resistance of about 20 Ω , a low mount impedance is required. A low mount impedance is also required to ease the design constraints of the thin-film tuner. Following standard design procedures and using experience gained with SIS mixers operating at similar wavelengths, a scale model mixer mount was designed in reduced height waveguide. Scale model measurements of the feed point impedance, located at the center of the suspended stripline filter (see Fig. 1(b)), were made for both quarter and half-height waveguide mixer mounts. A sliding backshort was used to condense and rotate the locus of this impedance onto the real axis of the Smith chart. From the scale model measurements, a standard length of 375 μm approximately a quarter of a guided wavelength, was chosen for the mixer back-section. By changing the length of the first low impedance section of the suspended stripline filter the feed point impedance could be increased or decreased. Using the half-height waveguide, for ease of fabrication, a length of 220 μm gave the desired value of 35 Ω . This impedance was transformed via a microstrip circuit fabricated with the SIS junction to achieve the required signal coupling at the junction.

A block diagram of the mixer circuit is given in Fig. 1(a). The fused quartz substrate, 5-mm-long \times 0.5-mm-wide \times 125- μm -thick, carrying the junction and filtering structure is

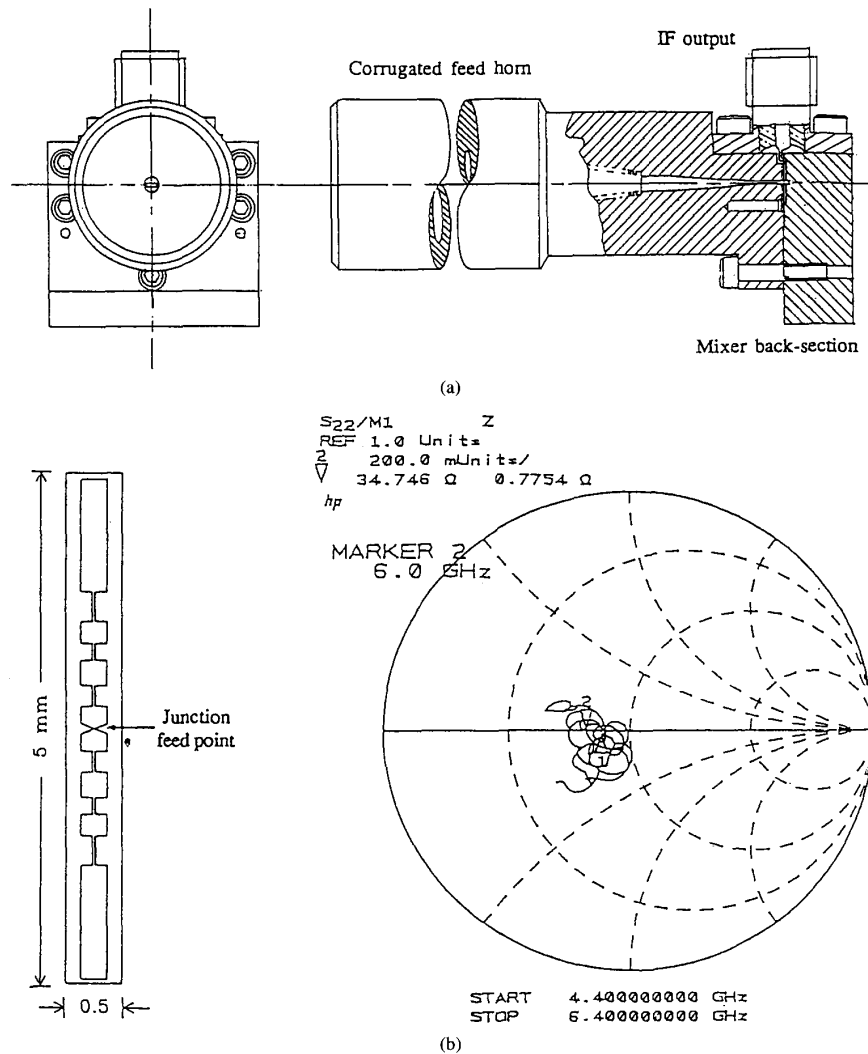

Fig. 1. (a) Mixer mount detail showing the corrugated horn feed and mixer back-section. (b) Suspended substrate filter layout and the locus of the junction feed point impedance.

sandwiched between the corrugated waveguide horn feed and a back-section containing a shorted section of waveguide. The low-pass filter design is also shown in the figure, the substrate is suspended with the metallization facing the corrugated horn feed. The measured feed point impedance is shown in Fig. 1(b). Measurements were made over the frequency range 4.4–6.4 GHz, and indicate that an instantaneous signal bandwidth of about 45% is possible with this design.

III. JUNCTION TUNING AND FABRICATION

In order to achieve wideband operation, an ωCR product of 2.3 (at 200 GHz) was chosen. For a reasonable match at the IF port, the normal state resistance of 17 Ω was used as the design goal. This implies the use of trilayer material with a current density of 7500 A cm^{-2} for a nominal junction area

of 1.5 μm^2 . The corresponding optimum source conductance was deduced from an empirical formula [4].

An integrated series inductive line and a two section impedance transformer, similar to that previously described [5], were used to match the optimum source conductance in parallel with the junction's geometric capacitance to the 35- Ω feed point impedance provided by the waveguide mount. The design of the matching network was performed with the help of Touchstone, taking the kinetic inductance of the superconducting strips into account, and is shown schematically in Fig. 2. Also shown in the figure is the calculated return loss for this arrangement as a function of signal frequency. Clearly, a reasonably good match, better than -10 dB, is possible over the required signal input bandwidth of 80 GHz.

The SIS junctions used in this receiver were made using optical lithographic techniques similar to those described in the

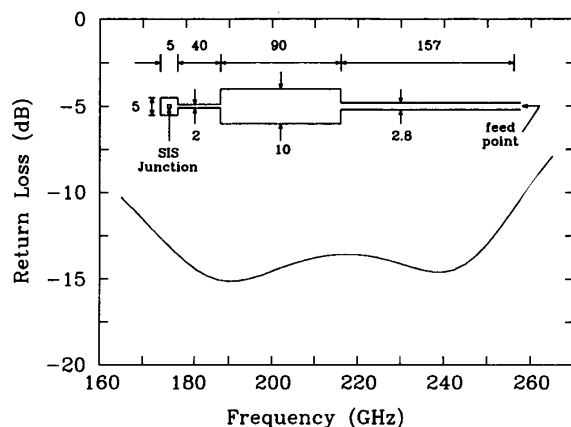

Fig. 2. Layout of the integrated microstripline tuning structure showing the SIS junction, the inductive line and the two step impedance transformer (dimensions in microns). Also shown is the calculated return loss across the signal frequency band.

literature [6]. In order to allow for some parameter variation during fabrication, three junction sizes were made, each with the same on-chip tuning circuit.

IV. RECEIVER PERFORMANCE

The SMA receiver package will consist of eight receivers, housed in a common cryostat and cooled using a closed-cycle helium refrigerator. For receiver noise measurements in the laboratory, however, it is more convenient to use a small liquid helium filled test dewar. Receiver noise measurements are made using the *Y*-factor method with room-temperature (295 K) and liquid nitrogen (77 K) cooled loads. Since the mixer has a wide signal input bandwidth, all receiver noise data should be considered double-side-band, and are obtained with the mixer at 4.2 K. A beamsplitter, presenting low-loss in the signal path, is used to combine signal and LO input to the mixer. The signals then pass through a laminated plastic vacuum window [7], a cooled porous Teflon window [8], and a Teflon lens, cooled to 4.2 K, before entering the mixer feed horn. We should note that no corrections were made for losses in front of the receiver.

The measured receiver noise as a function of local oscillator (LO) frequency for a number of different mixers is displayed in Fig. 3. For all these measurements, the IF amplifier network has a center frequency of 1.5 GHz, an instantaneous bandwidth of 500 MHz and a noise temperature of about 5 K. From the figure, the mixer incorporating the SIS junction with area $1.3 \mu\text{m}^2$ and normal resistance 22.5Ω , i.e., that closest to the nominal design ($1.5 \mu\text{m}^2$ and 17Ω , respectively), offers excellent low-noise performance over a band that is centered slightly lower than the design frequency, by about 3%. In an effort to push the operating band upwards, the same type of junction was used in a mixer whose back-section was shorter than that determined from scale model measurements, by about $60 \mu\text{m}$. In this case, the center frequency of the receiving band was increased by about 3%, i.e., to the desired value, with little change in average receiver noise. A junction with

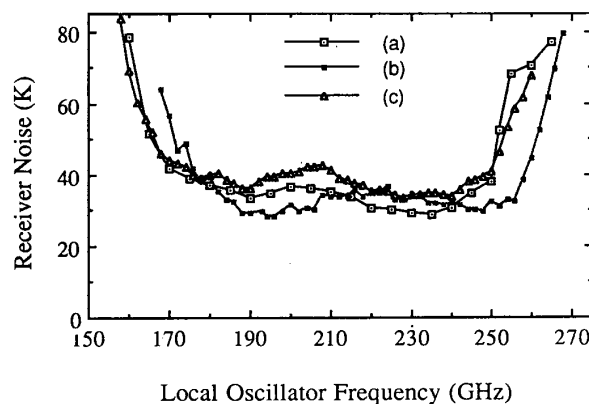

Fig. 3. The receiver noise is plotted as a function of LO frequency for three mixer configurations: (a) $1.3\text{-}\mu\text{m}^2$ junction in a mixer with the standard length back-section. (b) $1.3\text{-}\mu\text{m}^2$ junction in a mixer with the reduced length back-section. (c) $1.1\text{-}\mu\text{m}^2$ junction in a mixer with the reduced length back-section.

area $1.1 \mu\text{m}^2$ and normal resistance 27.5Ω was then tested in the original mixer. In this case, the receiver noise floor increased by about 5 K and the receiving band center remained unchanged. Clearly, any of the configurations tested offer performance, both in bandwidth and in noise, that will enable the SMA to start operations with state-of-the-art receivers. Furthermore, testing of a number of similar mixers indicates that the performance shown is readily achievable.

Standard measurement techniques [9]–[11] have been used to separate receiver noise into three major components: noise due to input losses, mixer noise, and multiplied IF noise. Fig. 4 shows the breakdown of noise for the receiver incorporating the mixer with the shorter back-section. With mixer noise close to the quantum limit at these frequencies, a total receiver noise of about 30 K should be considered as a good design goal, with about equal noise arising from input losses, mixer noise and multiplied IF noise. From the figure we observe that, while the individual sources of noise contribute about equally at some frequencies, there is an increase in noise arising from input losses at the band edges. This is mainly due to loss in the room-temperature window, designed for resonant transmission near the band center. Furthermore, truncation of the signal beam contributes additional noise at low frequencies. We also note that the mixer noise is relatively high at the center of the receiving band, and that some small reduction in noise may be possible as lower noise IF amplifiers become available.

In Fig. 5 we present current–voltage characteristics and IF output power curves for four different LO frequencies. The figure indicates that excellent mixer conversion is obtained at 230 GHz, good conversion at 180 and 205 GHz and poorer conversion at 255 GHz. We should note that only the LO frequency and drive level were changed between the different receiver noise measurements, all other parameters were fixed. In particular the mixer bias and magnetic field were held constant. This demonstrates that good receiver performance is readily achievable, optimization of receiver noise at all frequencies may require fine adjustment of all parameters. However, since only a slight improvement in sensitivity is

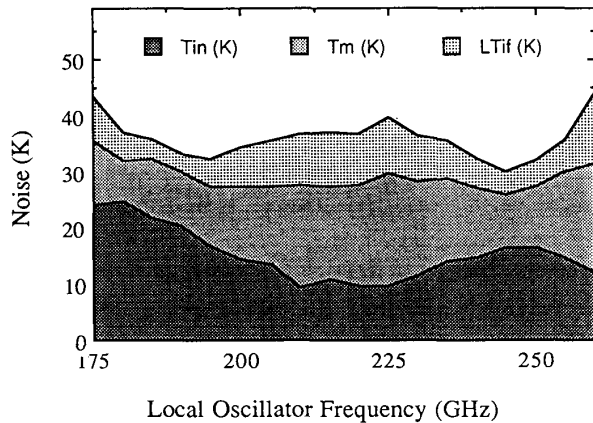

Fig. 4. A breakdown of receiver noise into its three components: input loss noise, T_{in} (K), mixer noise, T_m (K), and multiplied IF noise, LT_{if} (K) is plotted as a function of LO frequency for a mixer with reduced length back-section.

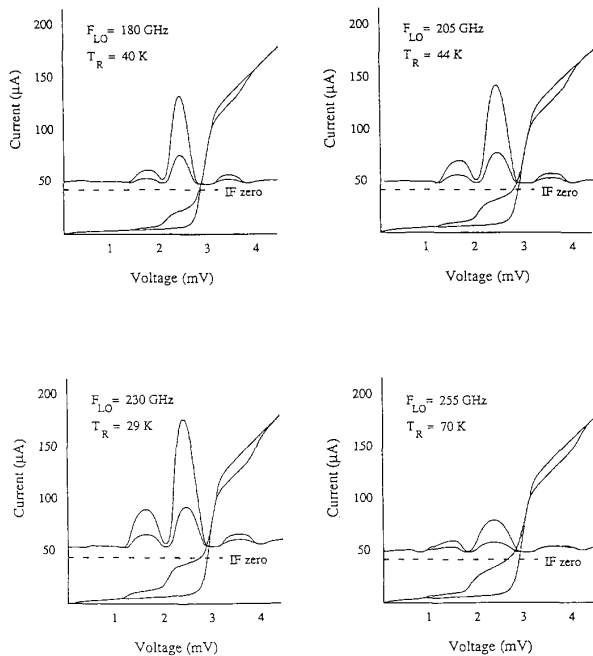

Fig. 5. Current-voltage characteristics, pumped and unpumped, are given for four different LO frequencies. Also shown is the receiver's output in response to hot (295 K) and cold (77 K) input loads.

expected, it is thought that further optimization may not be justified.

Finally, in Fig. 6, we show the receiver noise performance as a function of LO frequency for two different IF amplifier networks: one 500 MHz wide, centered at 1.5 GHz, the other 2.5 GHz wide, centered at 5 GHz—the IF of the SMA. Since the mixer gain is close to unity over a large part of the receiver's operating frequency, the difference in receiver noise is approximately equal to that of the IF amplifiers, i.e., about 7 K. The lowest measured receiver noise was typically 24 K for

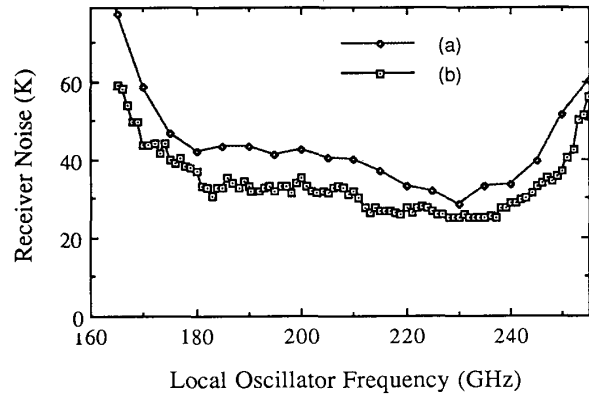

Fig. 6. The receiver noise is plotted as a function of LO frequency for two different IF's. (a) 1.5-GHz center frequency, 0.5-GHz bandwidth. (b) 5-GHz center frequency, 2.5-GHz bandwidth.

the 1.5 GHz IF and 30 K for the 5 GHz IF. From the figure, the receiver noise averaged over an 80 GHz input bandwidth is about 30 K for the 1.5 GHz IF and 40 K for the 5 GHz IF.

V. CONCLUSION

We have developed a wideband fixed-tuned SIS receiver for 200-GHz operation. The receiver noise is below 40 K across the majority of the observing band, about 80 GHz wide. Although some improvement may be possible through the use of lower-loss input optics and IF amplifiers offering superior noise performance to those currently available, it is thought that the current receiver design, which is particularly well adapted to duplication, will prevail and offer state-of-the-art performance when the SMA begins operations in 1997.

ACKNOWLEDGMENT

The authors would like to thank M. J. Smith for his superior technical assistance in developing the mixer used in this work.

REFERENCES

- [1] R. W. Wilson, K. B. Jefferts, and A. A. Penzias, "Carbon monoxide in the Orion nebula," *Astrophys. J.*, vol. 161, pp. L43-L44, July 1970.
- [2] K. B. Jefferts, A. A. Penzias, and R. W. Wilson, "Observation of the CN radical in the Orion nebula and in W51," *Astrophys. J.*, vol. 161, pp. L87-L89, Aug. 1970.
- [3] R. Blundell and C.-Y. E. Tong, "Submillimeter receivers for radioastronomy," *Proc. IEEE*, vol. 80, pp. 1702-1720, Nov. 1992.
- [4] Q. Ke and M. J. Feldman, "Optimum source conductance for high frequency superconducting quasiparticle receivers," *IEEE Trans. Microwave Theory Tech.*, vol. 41, pp. 90-95, 600-604, 1993.
- [5] T. H. Buttgenbach, H. G. LeDuc, P. D. Maker, and T. G. Phillips, "A fixed tuned broadband matching network for submillimeter SIS receivers," *IEEE Trans. Applied Supercond.*, vol. 2, pp. 165-175, 1992.
- [6] H. G. LeDuc, J. A. Stern, S. Thakoor, and S. Khanna, "All refractory NbN/MgO/NbN SIS tunnel junctions," *IEEE Trans. Magn.*, vol. MAG-23, pp. 863-865, 1987.
- [7] Hercules HR500/2S, a product of Hercules Inc., Wilmington, DE.
- [8] Zitex A, a product of Norton Performance Plastics, Wayne, NJ.
- [9] D. P. Woody, R. E. Miller, and M. J. Wengler, "85-115 GHz receivers for radio astronomy," *IEEE Trans. Microwave Theory Tech.*, vol. MTT-33, pp. 90-95, 1985.
- [10] R. Blundell, R. E. Miller, and K. H. Gundlach, "Understanding noise in SIS receivers," *Int. J. IR & MM Waves*, vol. 13, pp. 3-16, 1992.
- [11] Q. Ke and M. J. Feldman, "A technique for accurate noise temperature measurements for the superconducting quasiparticle receiver, in *Proc. 4th Int. Symp. Space Terahertz Technol.*, Los Angeles, CA, 1993, pp. 33-40.

Raymond Blundell (M'91), for a photograph and biography, see p. 388 of the March 1994 issue of this TRANSACTIONS.

Xiaolei Zhang, for photograph and biography, see p. 1274 of the August 1993 issue of this TRANSACTIONS.

Cheuk-Yu E. Tong (M'89), for a photograph and biography, see p. 388 of the March 1994 issue of this TRANSACTIONS.



D. Cosmo Papa joined the Massachusetts Institute of Technology in 1942. He worked in microwaves and mechanical engineering in the Radiation Laboratory and then in the Research Laboratory of Electronics. In 1961, he became part of the Radio Astronomy Group and continued there until 1988. In 1989, he joined the Submillimeter Receiver Laboratory at the Harvard-Smithsonian Center for Astrophysics in Cambridge, MA, where he is involved in the development of receivers in the submillimeter wavelength range.



Scott Paine received the B.S. degree in applied physics from the California Institute of Technology in 1984 and the Ph.D. degree in atomic physics from the Massachusetts Institute of Technology in 1992.

Since August 1992, he has been at the Submillimeter Receiver Laboratory of the Smithsonian Astrophysical Observatory. His current interests include millimeter- and submillimeter-wave techniques and numerical methods for optical beam propagation and diffraction.

Jeffrey A. Stern, for a photograph and biography, see p. 706 of the April 1994 issue of this TRANSACTIONS.



R. Louie Leombruno received the B.S. degree in mechanical engineering from Northeastern University, Boston, MA, in 1986.

Between 1986 and 1989 he was with Zeamer Systems Group, Hopkinton, MA, and was involved in the design and development of low-temperature test equipment for Superconductor Industry. Between 1989 and 1991 he was with Hughes Danbury Optical Systems and was involved with the Cryogenic Optics Research and Development Laboratory, SIRTf and AXAF. Since 1991 he has been at the Harvard-Smithsonian Center For Astrophysics, Cambridge, MA, where he is the Cryogenics Engineer of the Submillimeter Receiver Laboratory.

Henry G. LeDuc, for a photograph and biography, see p. 706 of the April 1994 issue of this TRANSACTIONS.

Bruce Bumble, photograph and biography not available at the time of publication.

Bruce Bumble, photograph and biography not available at the time of publication.